

Pump Guardian PG1

Specifications, Applications, Service Instructions & Parts

PUMP GUARDIAN PUMP CONTROLLER

for Refrigerant Recirculator
Packages, Accumulators,
Receivers and Intercoolers

INTRODUCTION

Hansen now offers the Pump Guardian, an easy to understand, integrated pump controller intended to safeguard refrigerant liquid pumps and to alert plant operators to improper or harmful operating conditions as they occur. Previously protective electrical circuits have depended upon mere time delay differential pressurestats for primary pump protection. However, if manual reset was used, the operator had to be alert and available to keep the plant running. If time delay with automatic restart was used, the pump would be repeatedly restarted even if a serious problem existed. This controller provides a centralized point of monitoring and protection for pumps. It can indicate relative pump status such as: running, cavitating, off due to low liquid level, insufficient or loss of pump pressure, motor overtemperature, and unnecessary on/off recycling.

APPLICATIONS

The Pump Guardian controller is ideal for use with refrigerant liquid pumps in recirculator packages, accumulators, receivers, and intercoolers. It is suitable for use with Hansen Hermetic pumps as well as other manufacturers' pumps, whether of open or sealless design.

KEY FEATURES

- Protects pump
- Avoids nuisance cutouts
- Clearly displays pump status
- Automatic operation
- Computer compatible

ADVANTAGES

The Pump Guardian is a fully integrated controller, designed specifically for use with industrial refrigeration pumps. It simplifies control circuit wiring, consolidates pump protecting devices, and keeps operator informed as to pump status. While monitoring pump activity, the Pump Guardian avoids nuisance cutouts and subsequent manual restarting of pump due to short-term conditions such as temporary or intermittent loss of proper refrigerant liquid supply to the pump inlet. Unlike most pump controls, it provides excess-recycling (on/off) protection to prevent unnecessary pump damage due to a reoccurring system problem without the need of a pressurestat manual reset. Motor overtemperature monitoring and protection is built-in for pumps having integral motor thermistors (as standard on Hansen CNF series pumps).

MATERIAL SPECIFICATIONS

- Power: 115V 50/60Hz; (230V 50/60Hz, optional)
- Terminal Strip: Accepts 14-22 AWG wire sizes
- Relays: 10 Amp, SPST, Normally Open (N.O.)
- Controller Temperature Range: 32°F to 120°F (0°C to 50°C)
- Enclosure: NEMA 4, high impact polycarbonate, clear cover, gasketed

INSTALLATION

Mount controller, which has a watertight enclosure, at “eye level” in an accessible indoor location away from potential impact or vibration. Use four screws (0.5” or longer) to fasten enclosure. See installation dimensions on page 4. Leave adequate space for electrical connections. A ½” conduit knockout (0.88” hole) is provided. Any additional conduit entrances must be located at the bottom of the enclosure to avoid possible dust and water damage to electronics.

Except during installation and possible servicing, the clear cover of the controller should remain on the enclosure and screwed tight. This will help prevent possible damage to controller by inadvertent water spray, physical damage or corrosive chemicals in the atmosphere.

INSTALLATION DIMENSIONS

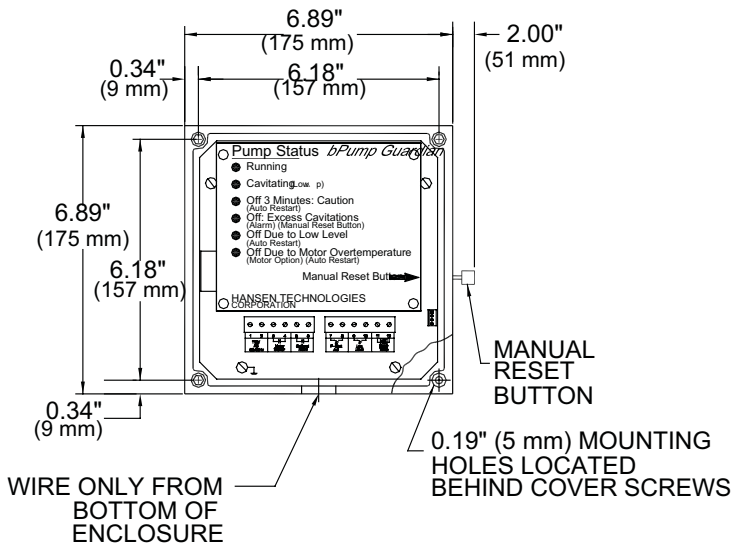

FRONT VIEW

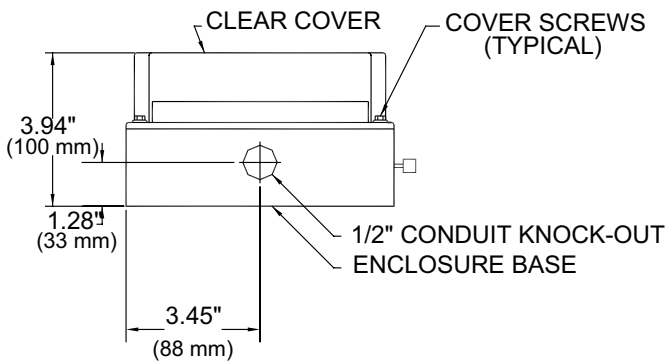

BOTTOM VIEW

PUMP STATUS

The Pump Status Lights visually indicate to the operator the pump activity. These bright LED lights are located on the front of controller and, when illuminated, can be seen from afar. Their functional meaning is described below:

RUNNING

This status light (green) is on anytime the pump is running and the motor starter relay (terminals 3 & 4) is closed. When pumping conditions are normal, this will be the only status light on.

CAVITATING (OR LOW ΔP)

If pump begins to cavitate or loses pumping pressure due to an absence of liquid at pump inlet and the pressure difference across pump drops below a preset value (10 psid), the differential pressurestat switch contacts open and the status light (amber) goes on.

OFF 3 MINUTES: CAUTION

This status light (red) indicates that the pump was CAVITATING continuously for 30 seconds and is now off (motor starter relay open) for 3 minutes. Afterwards, if conditions are normal, the pump will automatically restart (motor starter relay closed).

OFF: EXCESS CAVITATIONS

If controller turns pump off and on 6 times within an hour due to cavitation, this status light (red) goes on, the alarm relay (terminals 5 & 6) closes and pump will remain off (motor starter relay open). Alternately, if accumulated CAVITATING time within an hour reaches 6 minutes, the same result occurs except this status light will blink. If a system contains no liquid refrigerant, as for a noncommissioned new plant, the pump would be stopped (thereby protected from dry running) by this excess cavitations feature. In either case, the pump can be restarted (motor starter relay closed) by pushing the Manual Reset Button on the side of the controller. Whenever a pump is shutdown due to “excess cavitations”, it is important to determine what caused the condition and correct it promptly to avoid future incidents.

OFF DUE TO LOW LEVEL

If refrigerant liquid inside vessel drops below the low level float switch or other low level control, this status light (red) goes on and the pump turns off (motor starter relay open). If the level does not recover within a 1/2 hour, the alarm relay will close. When the liquid level rises above the low level point, including any differential, this status light goes off and the pump automatically restarts (motor starter relay closed).

OFF DUE TO MOTOR OVERTEMPERATURE

Hansen CNF series pumps have integral motor overtemperature thermistors inside the motor windings. When these thermistors are properly connected to controller (terminals 11 & 12), motor temperature can be accurately sensed. If motor becomes too hot, this status light (red) goes on and pump is turned off (motor starter relay open). If the motor does not cool down within a 1/2 hour, the alarm relay will close. When the temperature lowers sufficiently, the status light goes off and the pump automatically restarts (motor starter relay closed). This built-in feature replaces the need for the INT-69 motor overtemperature control device.

WIRING DIAGRAM

This wiring diagram is for illustration purposes only and does not show all controls and safety devices. Final control wiring is the responsibility of the system designer.

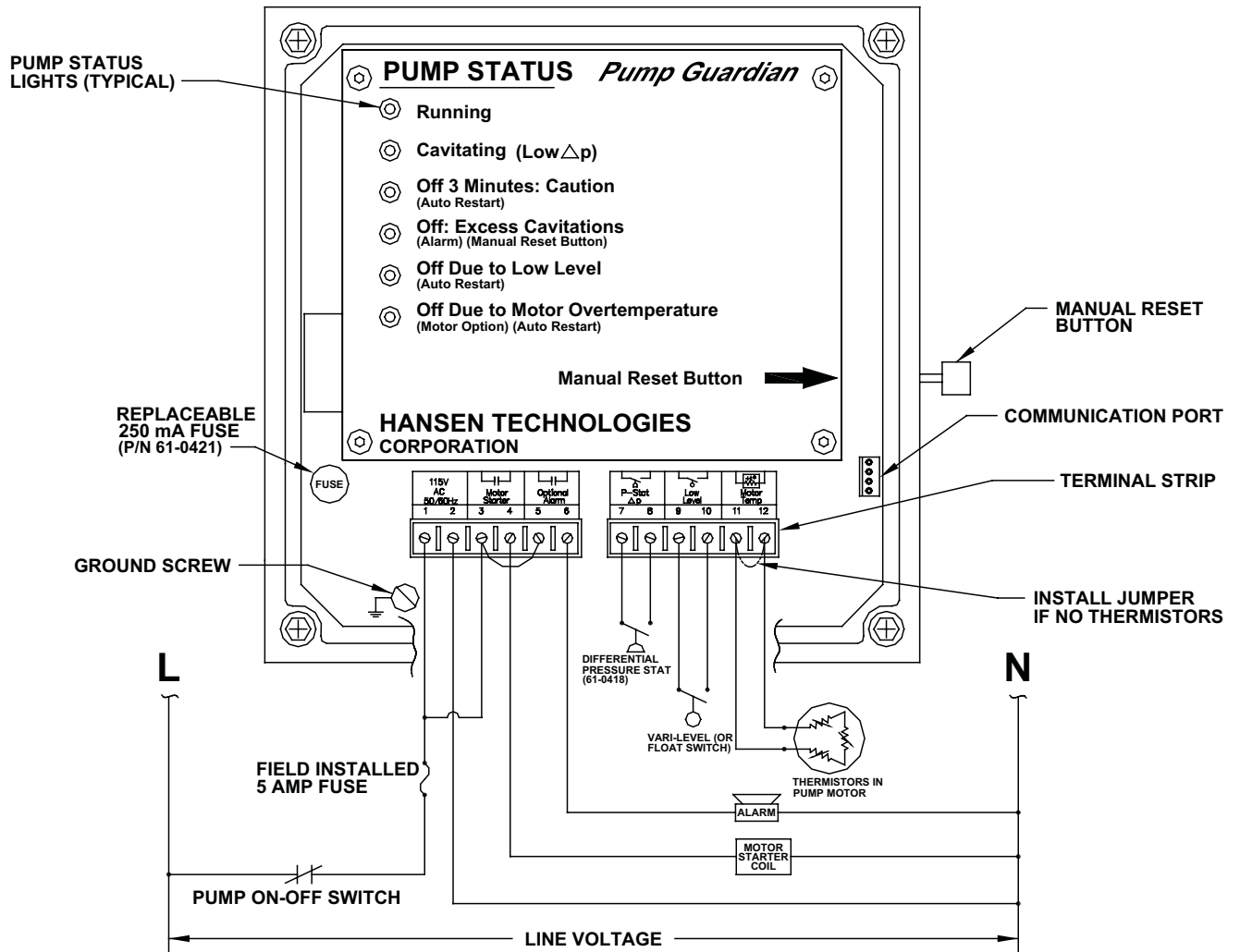

*Note: A non-time delay, non-manual restart differential pressurestat (such as 61-0418) is required. However, an existing differential pressurestat having a time delay relay can be field retrofitted to suit, see Hansen Sales Drawing #6100-73.

ELECTRICAL

The motor starter and alarm relays (terminals 3 & 4 and 5 & 6) are 10 AMP, SPST, Normally Open, dry contact relays. ("Dry contact" refers to a device in which an electrical connection is made by a pair of metallic contacts.) Circuits for these relays can be powered by line voltage. Conversely, the input terminals (7 thru 12) should never have line voltage applied to them. The differential pressurestat input (terminals 7 & 8) and low level input (terminals 9 & 10) require a dry contact, Normally Open switch or relay. The motor temperature input (terminals 11 & 12) normally requires a motor thermistor circuit. The controller will indicate pump motor overtemperature if the resistance at these terminals becomes greater than 4K ohms. If the pump motor does not have thermistors (such as Hansen CAM series pumps) or if non-Hansen pump thermistors are not compatible with this circuit, simply use a wire jumper across terminals 11 & 12 to bypass this feature.

Electrical power should be connected in series from the pump on-off switch to the controller. This is so the controller is powered only during desired pump run situations; otherwise erroneous alarms may occur. Install a 5 amp fuse to protect electrical circuits connected to the controller; see wiring diagram above. Before connecting electrical power to controller (terminals 1 & 2), check voltage on nameplate and power at the electrical leads to be sure they are the same. Supply voltage must be within +10% or -15% of nameplate voltage. A small, replaceable 250 mA fuse is located on circuit board to protect controller electronics; fuse p/n 61-0421.

DIFFERENTIAL PRESSURESTAT

A non-time delay, non-manual restart differential pressurestat (such as 61-0418) is required. This provides a dependable and economical pressure indicator for liquid refrigerant pumps. It enables the controller to detect a loss of pressure thus preventing the pump from running dry. The factory differential pressure setting is 10 psid.

Pressure is sensed across the inlet and outlet of the pump. Pump outlet pressure should be sensed at the 1/4" NPT fitting (discharge port adapter) located just below pump discharge flange. For non-Hansen pumps, use a fitting near pump discharge to sense outlet pressure. Pump inlet pressure should be sensed near the pump inlet on top of the suction line.

MANUAL RESET BUTTON

The Manual Reset Button is located on the right side of the controller enclosure. If an OFF: EXCESSIVE CAVITATIONS status occurs, this button must be momentarily pushed to restart pump (motor starter relay closed). Using the Manual Reset Button also resets the count of pump shutdowns (6 count) to zero; see OFF: EXCESSIVE CAVITATIONS in Pump Status section.

COMMUNICATIONS

The Pump Guardian has a computer compatible RS232 serial communications port. This port, in conjunction with a computer and communication software, enables access to additional information available from the microprocessor inside of the controller. This information includes: total number of cavitation shutdowns, total pump run time, total number of level and temperature shutdowns, input device status and more. Contact factory for the RS232 serial communications port specifications and field installation recommendations.

CAUTION

The Hansen Pump Guardian pump controller is only for use in refrigeration systems. These instructions and related safety precautions must be read completely and understood before selecting or using this controller. Only knowledgeable, trained refrigeration mechanics should install or operate this controller. Stated electrical and temperature ranges should not be exceeded. Any wiring and application diagrams provided are for illustration purposes only. The system designer has the final responsibility as to how this pump controller is connected and operated. The designer is also responsible for systems and components being designed to prevent abnormal pressures or velocity impact pressure surges. Where critical temperatures or products are involved, backup temperature controls or alarms are required. See also Safety Precautions in current List Price Bulletin and Safety Precautions Sheet supplied with product. Escaping refrigerant might cause personal injury, particularly to the eyes and lungs.

TYPICAL APPLICATION

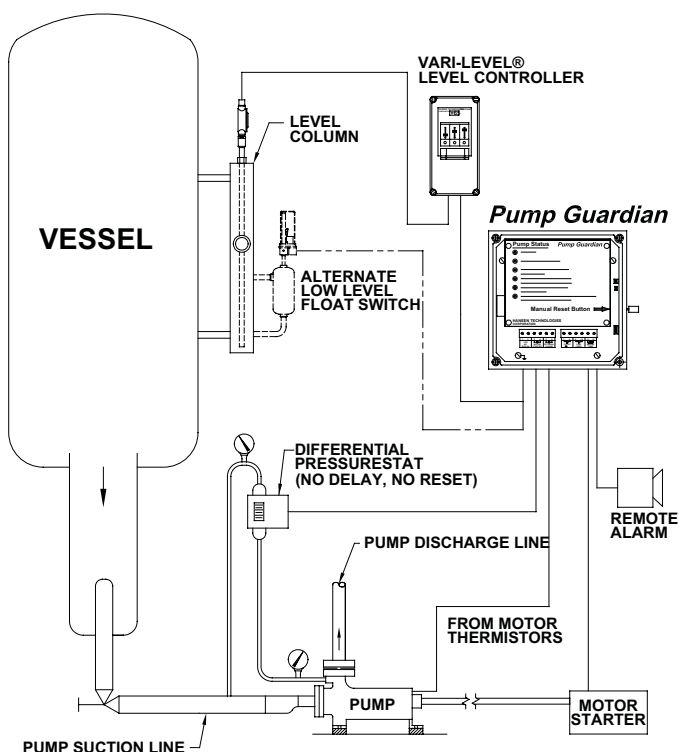

TYPICAL SPECIFICATIONS

“Pump controllers shall provide a means of protection against cavitation, dry running, low liquid level, excessive on-off recycling and motor overtemperature, and have manual reset capability, a communications port for computer monitoring, and a visual display of pump status, such as the Pump Guardian as manufactured by Hansen Technologies Corporation or approved equal.”

WARRANTY

Pump Guardian pump controllers are guaranteed against defective materials or workmanship for 90 days F.O.B. our plant. No consequential damages or field labor is included.

ORDERING INFORMATION

| CAT. NO. | DESCRIPTION |
|----------|---|
| PG1 | PUMP GUARDIAN Pump Controller with Watertight Enclosure |

Specify Catalog Number PG1 and Voltage (115V or 230V; 50/60Hz).

The Pump Guardian controller requires a differential pressurestat having no time delay and no manual reset. If needed, please also order differential pressurestat p/n 61-0418 when ordering controller.

HANSEN

Hansen Technologies Corporation
 6827 High Grove Boulevard
 Burr Ridge, Illinois 60527 USA
 Tel: 630.325.1565 Fax: 630.325.1572 Toll: 800.426.7368
 Email: info@hantech.com Web: www.hantech.com
 USA • Asia • Europe • India • Latin America • Middle East
 © 2006 Hansen Technologies Corporation